

# CAPACITIES AND SPECIFICATIONS

H2.0A, H2.5A6, H2.5A, H3.0A, H3.5A (H40A, H50A6, H60A, H70A) [R177]

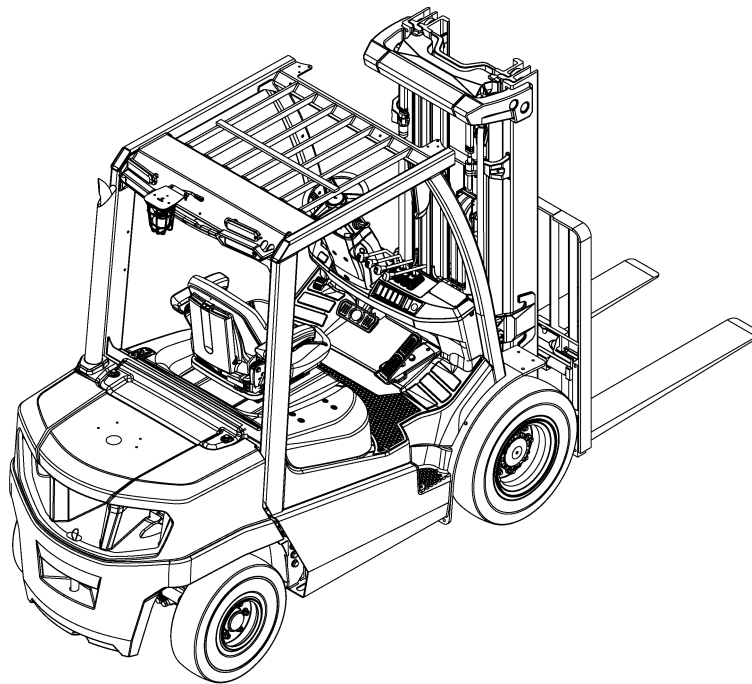

**HYSTER**

# SAFETY PRECAUTIONS

## MAINTENANCE AND REPAIR

- The Service Manuals are updated on a regular basis, but may not reflect recent design changes to the product. Updated technical service information may be available from your local authorized Hyster® dealer. Service Manuals provide general guidelines for maintenance and service and are intended for use by trained and experienced technicians. Failure to properly maintain equipment or to follow instructions contained in the Service Manual could result in damage to the products, personal injury, property damage or death.
- When lifting parts or assemblies, make sure all slings, chains, or cables are correctly fastened, and that the load being lifted is balanced. Make sure the crane, cables, and chains have the capacity to support the weight of the load.
- Do not lift heavy parts by hand; always use a lifting mechanism.
- Wear safety glasses.
- **DISCONNECT THE BATTERY** before doing any maintenance or repair on electric lift trucks. Disconnect the battery ground cable on internal combustion lift trucks.
- Always use correct blocks to prevent the unit from rolling or falling. See **HOW TO PUT THE LIFT TRUCK ON BLOCKS** in the **Operating Manual** or the **Periodic Maintenance** section of the service manual.
- Keep the unit clean and the working area clean and orderly.
- Use the correct tools for the job.
- Keep the tools clean and in good condition.
- Always use **HYSTER® APPROVED** parts when making repairs. Replacement parts must meet or exceed the specifications of the original equipment manufacturer.
- Make sure all nuts, bolts, snap rings, and other fastening devices are removed before using force to remove parts.
- Always fasten a **DO NOT OPERATE** tag to the controls of the unit when making repairs, or if the unit needs repairs.
- Strictly follow all **WARNING** and **CAUTION** notes in the operating manual, safety labels, service manual, and other instructions.
- Gasoline, Liquid Petroleum Gas (LPG), Compressed Natural Gas (CNG), Hydrogen Gas (H<sub>2</sub>), and Diesel fuels are flammable and potentially explosive. Hydraulic, transmission, and other fluids and oils are also flammable. Be sure to follow the necessary safety precautions when handling these substances or working on systems containing these substances.
- Lead acid batteries generate flammable gas when they are being charged. Keep fire and sparks away from the area. Make sure the area is well ventilated.
- Lithium-ion batteries should only be used in working environments where the temperature is within the recommended operating range (typically between 0 - 40°C (32 - 104°F)). Extreme temperatures, moisture, improper charging or damage to the battery can cause a fire or explosion.
- Whenever Diagnostic tools are needed for engine, only licensed or certified persons can use Diagnostic tools.

**NOTE:** The following symbols and words indicate safety information in this manual:



### **WARNING**

**Indicates a hazardous situation which, if not avoided, could result in death or serious injury.**



### **CAUTION**

**Indicates a hazardous situation which, if not avoided, could result in minor or moderate injury and property damage.**

On the lift truck, the **WARNING** symbol (and word, if present) are on orange background. The **CAUTION** symbol (and word, if present) are on yellow background.



**WARNING**

Installing improper electrical accessories or installing an electrical accessory incorrectly can increase the risk of equipment damage, personal injury and fire. **DO NOT** install electrical accessories to the truck unless you have been trained and authorized to do so. Personnel installing the electrical accessories must document the changes made to the truck. **DO NOT** install accessories which affect the truck's compliance with standard ANSI/ITSDF B56.1, UL 558, or UL 583, or which otherwise affect the safe operation of the truck.



**WARNING**

Installing improper electrical accessories or installing an electrical accessory incorrectly can increase the risk of equipment damage, personal injury and fire. **DO NOT** install electrical accessories to the truck unless you have been trained and authorized to do so. Personnel installing the electrical accessories must document the changes made to the truck. **DO NOT** install accessories which affect the truck's compliance with standard EN 1175:2020.



**WARNING**

California Proposition 65 - Operating, servicing and maintaining a powered industrial truck can expose you to chemicals including engine exhaust, carbon monoxide, phthalates, and lead, which are known to the State of California to cause cancer and birth defects or other reproductive harm. For more information, go to [www.P65Warnings.ca.gov](http://www.P65Warnings.ca.gov).



## TABLE OF CONTENTS

Introduction.....	1
General.....	1
Discharging the capacitors.....	1
Truck vital measurements.....	2
Weight specifications.....	2
Lift truck lifting capacity.....	2
Counterweight weights.....	2
Speed specifications.....	2
Engine speeds .....	2
Mast lower speeds .....	4
Carriage lifting speeds with metric rated load at governed RPM and 55°C oil temperature (+/- 5%).....	4
Front end equipment max drift speeds*.....	4
Dimension specifications.....	5
Tire sizes.....	5
Mast tilt specifications.....	5
Pressure specifications.....	6
Hydraulic system pressure specifications.....	6
Coolant system pressure specifications.....	6
Steering system pressure specifications.....	6
Tire pressure specifications.....	6
Transmission oil specifications.....	7
Engine operation specifications.....	7
Engine operation specifications.....	7
Fluid specifications and capacities.....	9
Fuel specifications and capacities.....	9
Fuel tank capacity.....	9
Lubricant specifications and capacities.....	10
Engine oil.....	10
Hydraulic tank oil.....	10
Transmission oil.....	11
Brake fluid.....	11
Dry brake axle.....	11
Wet brake axle.....	11
Coolant specifications and capacities.....	12
Cooling capacity.....	12
Heating Ventilation and Air Conditioning (HVAC) specifications.....	14
Torque specifications.....	16
Frame torque specifications.....	16
Energy, electrical, and controls systems torque specifications.....	16
Front end torque specifications.....	17
Carriage.....	17
Bolzoni fork positioner.....	17
Mast 2 stage FFL.....	17
Mast 3 Stage FFL.....	17
Mast 2 stage LFL.....	17
Mast 4 Stage FFL.....	18
Hydraulic torque specifications.....	18
Operator station torque specifications.....	19
Rectangle overhead guard.....	19
Figure 8 overhead guard.....	19
Drivetrain torque specifications.....	19
Engine - Yanmar 2.1L Diesel.....	19

**TABLE OF CONTENTS (Continued)**

Engine - Yanmar 2.2L LPG.....	20
Transmission.....	22
Drive axle (Dry Brake).....	22
Drive axle (Wet Brake).....	22
Brakes.....	22
Park brake.....	22
Steering axle.....	23

## Introduction

### GENERAL

#### 202001-001

**NOTE:** For any fasteners in this manual that feature standard torque specifications, please refer to **Metric and Inch (SAE) Fasteners 8000SRM0231** for correct specifications.

### DISCHARGING THE CAPACITORS



#### WARNING

**DO NOT** make repairs or adjustments unless you have been properly trained and authorized to do so. Improper repairs and adjustments can create dangerous operating conditions. **DO NOT** operate a lift truck that needs repairs. Report the need for repairs to your supervisor immediately. If repair is necessary, attach a **DO NOT OPERATE** tag on the steering wheel and disconnect the battery.

Disconnect the battery and discharge the capacitors before opening any compartment covers or inspecting or repairing the electrical system. **DO NOT** place tools on top of the battery. If a tool causes a short circuit, the high current flow from the battery can cause personal injury or property damage.

Some check and adjustments are performed with the battery connected. **DO NOT** connect the battery until the procedure instructs you to do so. Never wear any metallic items on your fingers, arms, or neck. Metal items can accidentally make an electrical connection and cause injury. Before performing any tests or adjustments, block the lift truck to prevent unexpected movement.

The capacitors in the transistor controller(s) can hold an electrical charge for about 10 minutes after the battery is disconnected. To prevent an electrical shock and personal injury, discharge the capacitor(s) before inspecting or repairing any component in the drive unit compartment. Make certain that the battery had been disconnected.

**DO NOT** short across the motor controller terminals with a screwdriver or jumper wire.

**Make certain the Emergency-Stop Switch has not been activated. This will isolate the controller and prevent the capacitors from discharging properly. The proper way to disconnect the battery is by separating the battery connectors.**

**DISCHARGING THE CAPACITORS:** For trucks with rapid-charge option, the horn cannot be used to discharge capacitors prior to service. Disconnect the battery, then wait five minutes before performing any service on the truck.

1. Ensure the capacitors are discharged by performing Step 2 through Step 6 below.
2. Turn the key or keyless switch to **OFF** position.
3. Disconnect the battery by separating the connector on the battery cable from the connector on the lift truck.
4. Block the drive wheels to prevent the lift truck from moving.
5. Make sure the Emergency-Stop Switch **HAS NOT** been activated. If the Emergency-Stop Switch is activated, rotate the switch to the right until it pops up.
6. Press the horn button on the steering column. Wait 30 seconds to be sure capacitors are fully discharged. If the horn does not sound when the switch is actuated, wait 10 minutes before proceeding with service.  
For lift trucks equipped with rapid-charge option, the horn cannot be used to discharge capacitors prior to service. Disconnect the battery, then wait five minutes before performing any service on the truck.

## Truck vital measurements

### WEIGHT SPECIFICATIONS

202001-177

#### LIFT TRUCK LIFTING CAPACITY

Model	Weight
H2.0A(H40A)	1814 kg (4000 lb)
H2.5A/2.5A6(H50A)	2268 kg (5000 lb)
H3.0A(H60A)	2722 kg (6000 lb)
H3.5A(H70A)	3175 kg (7000 lb)

#### COUNTERWEIGHT WEIGHTS

Model	Weight
H2.0A(H40A)	978 kg (2156 lb)
H2.5A(H50A)	1355 kg (2987 lb)
H2.5A6(H50A)	1554 kg (3426 lb)
H3.0A(H60A)	1737 kg (3829 lb)
H3.5A(H70A)	2092 kg (4612 lb)

### SPEED SPECIFICATIONS

202001-178

#### ENGINE SPEEDS

Model: H2.0-3.5A, H2.5A6 (H40-70A) R177	
Yanmar 2.1L Diesel	
Low idle speed *	860-890 rpm
High idle speed (STD)	2515-2545 rpm
High idle speed (ECO)	1985-2015 rpm
Stall speed <50 hrs (STD) (w/o CAC)	1763-1963 rpm
Stall speed >50 hrs (STD) (w/o CAC)	1813-2013 rpm
Stall speed <50 hrs (STD) (with CAC)	1914-2114 rpm
Stall speed >50 hrs (STD) (with CAC)	1964-2164 rpm
Stall speed <50 hrs (ECO) (w/o CAC)	1763-1963 rpm
Stall speed >50 hrs (ECO)(w/o CAC)	1813-2013 rpm
Stall speed <50 hrs (ECO) (with CAC)	1900-2100 rpm
Stall speed >50 hrs (ECO) (with CAC)	1900-2100 rpm

Model: H2.0-3.5A, H2.5A6 (H40-70A) R177	
Yanmar 2.2L LPG	
Low idle speed *	860-890 rpm
High idle speed (STD)	2515-2545 rpm
High idle speed (ECO)	2515-2545 rpm
Stall speed <50 hrs (STD)	1895-2095 rpm
Stall speed >50 hrs (STD)	1920-2120 rpm
Stall speed <50 hrs (ECO)	1600-1800 rpm
Stall speed >50 hrs (ECO)	1600-1800 rpm
Yanmar 2.2L Bi-Fuel	
Low idle speed *	860-890 rpm
High idle speed (STD)	2515-2545 rpm
High idle speed (ECO)	2515-2545 rpm
Stall speed <50 hrs (STD) (LPG)	1800-2000 rpm
Stall speed >50 hrs (STD) (LPG)	1820-2020 rpm
Stall speed <50 hrs (ECO) (LPG/GAS)	1650-1850 rpm
Stall speed >50 hrs (ECO) (LPG/GAS)	1650-1850 rpm
Yanmar 3.0L Diesel	
Low idle speed *	850-900 rpm
High idle speed (STD)	2425-2475 rpm
High idle speed (ECO)	N/A
Stall speed <50 hrs (STD)	1837-2037 rpm
Stall speed >50 hrs (STD)	1937-2137 rpm
Stall speed <50 hrs (ECO)	N/A
Stall speed >50 hrs (ECO)	N/A
Yanmar 3.3L Diesel	
Low idle speed *	850-900 rpm
High idle speed (STD)	2575-2625 rpm
High idle speed (ECO)	N/A
Stall speed <50 hrs (STD)	1970-2170 rpm
Stall speed >50 hrs (STD)	2080-2280 rpm
Stall speed <50 hrs (ECO)	N/A
Stall speed >50 hrs (ECO)	N/A
*Measure low idle speed with coolant temperature above 30°C (86°F) for 2.1L diesel or 65.5°C (150°F) for 2.2L spark ignited engines. Low idle speed will be raised up to 1000 rpm at lower coolant level temperatures. Low idle speed is raised to 1000 rpm when cab electrical options are activated.	
<b>NOTE:</b> Transmission oil must be heated to 50°C (122°F). See <b>Periodic Maintenance</b> 8000SRM2305 <b>Periodic Maintenance</b> 8000SRM2305 for procedure.	

**MAST LOWER SPEEDS**

Model: H2.0-3.5A, H2.5A6 (H40-70A) R177		
Mast	2.0-2.5t	3.0-3.5t
2 stage LFL	0.58 m/s (1.90 ft/s)	0.57 m/s (1.87 ft/s)
2 stage FFL	0.52 m/s (1.71 ft/s)	0.55 m/s (1.80 ft/s)
3 Stage FFL	0.55 m/s (1.80 ft/s)	0.55 m/s (1.80 ft/s)

**CARRIAGE LIFTING SPEEDS WITH METRIC RATED LOAD AT GOVERNED RPM AND 55°C OIL TEMPERATURE (+/- 5%)**

Model: H2.0-3.5A, H2.5A6 (H40-70A) R177					
Mast	Pump	2.0-2.5t, 2.5t6		3.0-3.5t	
		NL	RL	NL	RL
2 stage LFL	Gear	0.67 m/s (2.20 ft/s)	0.65 m/s (2.13 ft/s)	0.62 m/s (2.03 ft/s)	0.60 m/s (1.97 ft/s)
	VDP	0.67 m/s (2.20 ft/s)	0.65 m/s (2.13 ft/s)	0.62 m/s (2.03 ft/s)	0.60 m/s (1.97 ft/s)
2 stage FFL	Gear	0.60 m/s (1.97 ft/s)	0.58 m/s (1.90 ft/s)	0.60 m/s (1.97 ft/s)	0.58 m/s (1.90 ft/s)
	VDP	0.60 m/s (1.97 ft/s)	0.58 m/s (1.90 ft/s)	0.60 m/s (1.97 ft/s)	0.58 m/s (1.90 ft/s)
3 Stage FFL	Gear	0.63 m/s (2.07 ft/s)	0.61 m/s (2.00 ft/s)	0.60 m/s (1.97 ft/s)	0.58 m/s (1.90 ft/s)
	VDP	0.63 m/s (2.07 ft/s)	0.61 m/s (2.00 ft/s)	0.60 m/s (1.97 ft/s)	0.58 m/s (1.90 ft/s)

**FRONT END EQUIPMENT MAX DRIFT SPEEDS\***

Model: H2.0-3.5A, H2.5A6 (H40-70A) R177		
Hydraulic oil	Max vertical drift at carriage	Max tilt drift
Temperature	mm/min (in./min)	degrees/min
20°C (68°F)	2.2 mm/min (0.09 in./min)	0.11
25°C (77°F)	3.0 mm/min (0.12 in./min)	0.15
30°C (86°F)	3.9 mm/min (0.15 in./min)	0.20
35°C (95°F)	5.1 mm/min (0.20 in./min)	0.25
40°C (104°F)	6.5 mm/min (0.26 in./min)	0.32
45°C (113°F)	8.1 mm/min (0.32 in./min)	0.40
50°C (122°F)	10 mm/min (0.39 in./min)	0.50
55°C (131°F)	12.1 mm/min (0.48 in./min)	0.61
60°C (140°F)	14.5 mm/min (0.57 in./min)	0.73

\*Measure the vertical drift with rated load hoisted above the free lift. Measure tilt drift with rated load at 2.5 m (8.20 ft)

## DIMENSION SPECIFICATIONS

### 202001-179

#### TIRE SIZES

Model: H2.0-3.5A, H2.5A6 (H40-70A) R177			
Tire function	Tire size	Tire type	Manufacturer
Drive tires	28 x 9 - 15	Solid and Solid (Non-Marking) pneumatic	Trelleborg
	28 x 9 - 15	Bias-Ply and Radial pneumatic	Multiple
	7.00 x 12 Dual	Bias Ply pneumatic	Trelleborg
	7.00 - 12	Solid and Solid (Non-Marking) pneumatic	Trelleborg
	7.00 - 12	Bias-Ply and Radial pneumatic	Miltiple
	5.50 - 15	Solid and Solid (Non-Marking) pneumatic	Trelleborg
	6.00 - 15	Solid and Solid (Non-Marking) pneumatic	Trelleborg
Steer tires	6.00 - 9	Solid and Solid (Non-Marking) pneumatic	Trelleborg
	6.00 - 9	Bias Ply pneumatic	Multiple
	6.00 - 9	Radial pneumatic	Michelin
	6.50 - 10	Solid and Solid (Non-Marking) pneumatic	Trellborg
	6.50 - 10	Bias-Ply and Radial pneumatic	Trellborg

#### MAST TILT SPECIFICATIONS

Model: H2.0-3.5A, H2.5A6 (H40-70A) R177	
Mast tilt angle: 6°fwd/6°bwd	fwd: +1°/-0.5° bwd: +0°/-0.5°
Mast tilt angle: 10°fwd/6°bwd	fwd: +1°/-0.5° bwd: +0°/-0.5°
Tilt angle sensor angle bwd	Verify tilt angle readout on display is within: +2°, -0.5° of max configured mast back tilt angle
Tilt angle sensor angle vertical	Verify tilt angle readout on display is within: +0°, ± 0.5° of vertical
Tilt angle sensor fwd	Verify tilt angle readout on display is within: +0.5°, -2° of max configured mast fwd tilt angle
Mast tilt-racking	Verify no racking at either end of cylinder stroke
Mast lift-racking	Verify no racking at either end of cylinder stroke

Model: H2.0-3.5A, H2.5A6 (H40-70A) R177	
Test carriage drift	With mast vertical and RL at 2.5 m (8.2 ft), verify the carriage does not drift more than 100 mm (4 in.) in 10 minutes
Test tilt drift	With mast vertical and RL at 2.5 m (8.2 ft), verify the mast tilt angle does not drift more than 5° in 10 minutes
Functional test > 10 C	Lift rated load to full extension-verify smooth operation
Functional test < 10 C	Tilt rated load (at 250 to 500 mm (5 to 6 in.)) both directions-verify smooth operation
Tilt speed (fwd and bwd)	5°/Second

## PRESSURE SPECIFICATIONS 202001-180

### HYDRAULIC SYSTEM PRESSURE SPECIFICATIONS

Model: H2.0-3.5A, H2.5A6 (H40-70A) R177		
Item	Pressure reading	
	2.0-2.5t	2.5t6, 3.0-3.5t
Primary relief valve	24 MPa (3481 psi)	24 MPa (3481 psi)
Secondary relief valve	18 MPa (2611 psi)	18 MPa (2611 psi)

### COOLANT SYSTEM PRESSURE SPECIFICATIONS

Model: H2.0-3.5A, H2.5A6 (H40-70A) R177	
Item	Pressure reading
Cooling system pressure	100 kPa (14.5 psi)

### STEERING SYSTEM PRESSURE SPECIFICATIONS

Model: H2.0-3.5A, H2.5A6 (H40-70A) R177	
Relief pressure: Oil @ 50-65°C (122-149°F)	14.0 ±0.5 MPa (2030.5 ±72.5 psi) at 800RPM
Number of turns lock to lock	4
2.0-3.0t	Units should steer lock to lock with zero travel speed.
3.5t	Units should steer lock to lock with slight travel speed [example, 3 kph (2 mph)]

### TIRE PRESSURE SPECIFICATIONS

Model: H2.0-3.5A, H2.5A6 (H40-70A) R177	
Tire function	Recommended pressure
Drive tires	10 bar (145 psi)
Steer tires	9 bar (131 psi)

**TRANSMISSION OIL SPECIFICATIONS****Table 1. Dry brake axle**

Model: H2.0-3.5A, H2.5A6 (H40-70A) R177						
Torque Converter speed	Charge pressure	FWD pack	REV pack	Cooler flow	Torque Converter pressure	Cold pressure relief
800 rpm	>8.5 bar (123 psi)	8-10 bar (116-145 psi)	8-10 bar (116-145 psi)	>8.7 bar (126 psi)	1.2-2 bar (17.4-29 psi)	17.5 bar (254 psi)
2500 rpm	<11 bar (159.5 psi)	8-13.5 bar (116-195.8 psi)	8-13.5 bar (116-195.8 psi)	>21 bar (305 psi)	5-6 bar (72.5-87 psi)	17.5 bar (254 psi)

**Table 2. Wet brake axle**

Model: H2.0-3.5A, H2.5A6 (H40-70A) R177							
System pressure	Torque Converter speed	Charge pressure	FWD pack	REV pack	Cooler flow	Torque Converter pressure	Cold pressure relief
Low pressure	800 rpm	>8.5 bar (123 psi)	8-10 bar (116-145 psi)	8-10 bar (116-145 psi)	>12 bar (174 psi)	1.2-2 bar (17.4-29 psi)	65 bar (943 psi)
	2500 rpm	<13 bar (189 psi)	8-14.5 bar (116-210.3 psi)	8-14.5 bar (116-195.8 psi)	>31 bar (450 psi)	5-6 bar (72.5-87 psi)	65 bar (943 psi)
High pressure	800 rpm	>57 bar (827 psi)	8-10 bar (116-195.8 psi)	8-10 bar (116-195.8 psi)	>8 bar (116 psi)	0.8-2 bar (12-29 psi)	65 bar (943 psi)
	2500 rpm	<63 bar (914 psi)	8-13.5 bar (116-195.8 psi)	8-13.5 bar (116-195.8 psi)	>27 bar (392 psi)	5-6 bar (72.5-87 psi)	65 bar (943 psi)

**ENGINE OPERATION SPECIFICATIONS  
202001-212****ENGINE OPERATION SPECIFICATIONS**

Model: H2.0-3.5A, H2.5A6 (H40-70A) R177	
Yanmar 2.1L Diesel	
Displacement	2091 cc
Compression pressure	3.14 MPa (455.4 psi)
Thermostat: cracking	71°C (159.8°F)
Thermostat: full open	85°C (185°F)
Valve clearance: intake (cold)	0.15 to 0.25 mm (0.006 to 0.010 in.)
Valve clearance: exhaust (cold)	0.15 to 0.25 mm (0.006 to 0.010 in.)
Firing order	1-3-4-2
Timing	Gear-not adjustable
Oil pressure	No oil pressure sensor, only switch

<b>Model: H2.0-3.5A, H2.5A6 (H40-70A) R177</b>	
<b>Yanmar 2.2L LPG/Bi-Fuel</b>	
<b>Displacement</b>	2189 cc
<b>Compression pressure</b>	0.92 MPa (133.4 psi) min at 300 RPM
<b>Thermostat: cracking</b>	71°C (159.8°F)
<b>Thermostat: full open</b>	85°C (185°F)
<b>Valve clearance: intake (cold)</b>	0.15 to 0.25 mm (0.006 to 0.010 in.)
<b>Valve clearance: exhaust (cold)</b>	0.15 to 0.25 mm (0.006 to 0.010 in.)
<b>Firing order</b>	1-3-4-2
<b>Timing</b>	Gear-not adjustable
<b>Oil pressure</b>	No oil pressure sensor, only switch
<b>End Of Line hot test</b>	Pass*
<b>Yanmar 3.0L Diesel</b>	
<b>Displacement</b>	3053 cc
<b>Compression pressure</b>	2.35 MPa (340.8 psi) min at 250 RPM
<b>Thermostat: cracking</b>	71°C (159.8°F)
<b>Thermostat: full open</b>	85°C (185°F)
<b>Valve clearance: intake (cold)</b>	0.15 to 0.25 mm (0.006 to 0.010 in.)
<b>Valve clearance: exhaust (cold)</b>	0.15 to 0.25 mm (0.006 to 0.010 in.)
<b>Firing order</b>	1-3-4-2
<b>Timing</b>	Gear-not adjustable
<b>Oil pressure</b>	No oil pressure sensor, only switch
<b>Yanmar 3.3L Diesel</b>	
<b>Displacement</b>	3319 cc
<b>Compression pressure</b>	2.35 MPa (340.8 psi) min at 250 RPM
<b>Thermostat: cracking</b>	71°C (159.8°F)
<b>Thermostat: full open</b>	85°C (185°F)
<b>Valve clearance: intake (cold)</b>	0.15 to 0.25 mm (0.006 to 0.010 in.)
<b>Valve clearance: exhaust (cold)</b>	0.15 to 0.25 mm (0.006 to 0.010 in.)
<b>Firing order</b>	1-3-4-2
<b>Timing</b>	Gear-not adjustable
<b>Oil pressure</b>	No oil pressure sensor, only switch
*Run End Of Line (EOL) hot test for all 2.2L LPG and Bi-Fuel engines. Report EOL test results and s/n's to Yanmar.	

## Fluid specifications and capacities

### FUEL SPECIFICATIONS AND CAPACITIES

202001-181

#### FUEL TANK CAPACITY

Model	Fuel Type	Quantity	Specifications
H2.0-3.5A, H2.5A6 (H40-70A) R177	Diesel	35.62 liter (9.41 gal)	2.1L Diesel (DPF or DOC): Ultra-Low Sulfur Diesel, (Max 15 ppm sulfur)-less than 500 ppm preferred. Bio-diesel up to B20. 3.0L/3.3L Diesel (Non-emissions): Max 5000 ppm sulfur-less than 500 ppm preferred. Bio-diesel up to B20. See NOTE
H2.0-3.5A, H2.5A6 (H40-70A) R177	LPG	15 kg (33.1 lb)	HD-5
H2.0-3.5A, H2.5A6 (H40-70A) R177	Gasoline	35.62 liter (9.41 gal)	87 octane pump gasoline

#### Diesel fuel specifications required by 2.1L engine

**NOTE:**
**Diesel Fuel should comply with the following specifications**

1. Compliance is required with EN590, ASTM D975 or JIS K2204
2. The following requirements also need to be fulfilled:
  - Sulfur content of the diesel fuel should be less than 15ppm.
  - Water and sediment in the diesel fuel should not exceed 200mg/kg.
  - Ash should not exceed 0.01% by mass.
  - Aluminum, silicon and magnesium should be below 1ppm.
  - Free of zinc and sodium.
  - Total contamination should not exceed 24mg/kg.

**Prohibition**

- Never use kerosene.
- Never mix kerosene with diesel fuel.
- Never use residual fuels that cause diesel filter fuel clogging and carbon deposits on the injectors.
- Never use fuels stored for a long time in a drum, can, or similar container.
- Never mix used engine oil with diesel fuel.

## LUBRICANT SPECIFICATIONS AND CAPACITIES

### 202001-182

#### ENGINE OIL

Model: H2.0-3.5A, H2.5A6 (H40-70A) R177			
Engine	Quantity	Specifications	
		Temp. Range	Viscosity
Yanmar 2.1L Diesel	7.4 liter (7.8 qt)	-25 to 30°C (-13 to 86°F)	SAE 5W-30
		-20 to 30°C (-4 to 86°F)	SAE 10W-30
		-16 to 40°C (3.2 to 104°F)	SAE 15W-40
		CJ-4 or CK-4	
		Temp. Range	Viscosity
Yanmar 2.2L LPG	7.4 liter (7.8 qt)	-25 to 30°C (-13 to 86°F)	SAE 5W-30
		-20 to 30°C (-4 to 86°F)	SAE 10W-30
		-16 to 40°C (3.2 to 104°F)	SAE 15W-40
		API SM or API SN	
		Temp. Range	Viscosity
Yanmar 3.0L or Yanmar 3.3L Diesel	9.4 liter (9.9 qt)	-25 to 30°C (-13 to 86°F)	SAE 5W-30
		-20 to 30°C (-4 to 86°F)	SAE 5W-30
		-16 to 40°C (3.2 to 104°F)	SAE 5W-30
		API CK-4 & SN	

**NOTE:** Yanmar 2.2L LPG ONLY- If following a 1000 hour oil change schedule, engine oil used must be either "Shell Rotella T6 5W-30 Multi Vehicle" or "Shell Rimula R6 LME Plus 5W-30". If following a 500 hour oil change schedule, engine oil used must be API SM or SN for 2.2L LPG

#### HYDRAULIC TANK OIL

H2.0-3.5A, H2.5A6 (H40-70A) R177			
Configuration	Ambient Temp.	Hydraulic Temp.	Fluid Type
Gear Pump	-40 to 30°C (-40 to 86°F)	-15 to 100°C (5 to 212°F)	N/A
	-15 to 40°C (5 to 104°F)	-15 to 100°C (5 to 212°F)	ISO VG 46
	0 to 40°C (32 to 104°F)	-15 to 100°C (5 to 212°F)	ISO VG 46

<b>H2.0-3.5A, H2.5A6 (H40-70A) R177</b>			
<b>Configuration</b>	<b>Ambient Temp.</b>	<b>Hydraulic Temp.</b>	<b>Fluid Type</b>
Variable Displacement Pump Powershift transmission	-40 to 30°C (-40 to 86°F)	-40 to 75°C (-40 to 167°F)	ISO 6743-4
	-15 to 40°C (5 to 104°F)	-15 to 100°C (5 to 212°F)	ISO VG 46
	0 to 50°C (32 to 122°F)	-20 to 110°C (32 to 230°F)	JDM J20C
Hydrostatic transmission	All	All	JDM J20C

**TRANSMISSION OIL**

<b>Model</b>	<b>Transmission</b>		<b>Quantity</b>	<b>Specifications</b>
H2.0-3.5A, H2.5A6 (H40-70A) R177	Powershift (1-3 ton Basic)	Dry brake	9 liter (9.5 qt)	J20C
		Wet brake	9 liter (9.5 qt)	J20C
	Hydrostatic	Dry brake	<b>Chain drive case</b>	J20C
			2 liter (2.1 qt)	
		Wet brake	<b>Chain drive case</b>	J20C
			2 liter (2.1 qt)	

**BRAKE FLUID**

<b>Model</b>	<b>Quantity</b>	<b>Specifications</b>
H2.0-3.5A, H2.5A6 (H40-70A) R177 Model:	<b>Dry brake</b>	SAE J-1703 (DOT 3) or SAE J-1704 (DOT 4)
	0.25 liter (0.26 qt)	
	<b>Wet brake</b>	Dexron III from sealed container
	0.35 liter (0.37 qt)	

**DRY BRAKE AXLE**



<b>Model</b>	<b>Quantity</b>	<b>Specifications</b>
H2.0-3.5A, H2.5A6 (H40-70A) R177	2.0 liter (2.11 qt)	80W 90



**WET BRAKE AXLE**

<b>Model</b>	<b>Quantity</b>	<b>Specifications</b>
Model: H2.0-3.5A, H2.5A6 (H40-70A) R177	<b>Differential</b>	80W 90
	1.3 liter (1.4 qt)	
	<b>Brake cooling</b>	J20C
	7.0 liter (7.4 qt)	

**COOLANT SPECIFICATIONS AND CAPACITIES  
202001-183**

**COOLING CAPACITY**

Model: H2.0-3.5A, H2.5A6 (R177)		
Engine	Quantity	Specifications
Yanmar 2.1L diesel Yanmar 2.2L LPG	10.5 liter (11.1 qt)	 <b>CAUTION</b> <b>Additives may damage the cooling system. Before using additives, contact your local Hyster dealer.</b>  Trucks built prior to May 2021, use either a 50% water/50% ethylene-glycol boron free, silicate free mixture or BASF® Glysantin® G40 coolant. Protects cooling system down to -37°C (-34.6°F)  Trucks built after May 2021, use Valvoline Zerex G40 coolant. Protects cooling system down to -37°C (-34.6°F)
Yanmar 3.0-3.3L diesel	11.5 liter (12.2 qt)	 <b>CAUTION</b> <b>Additives may damage the cooling system. Before using additives, contact your local Hyster dealer.</b>  Trucks built prior to May 2021, use either a 50% water/50% ethylene-glycol boron free, silicate free mixture or BASF® Glysantin® G40 coolant. Protects cooling system down to -37°C (-34.6°F)  Trucks built after May 2021, use Valvoline Zerex G40 coolant. Protects cooling system down to -37°C (-34.6°F)

Model: H40-70A (R177)		
Engine	Quantity	Specifications
Yanmar 2.1L diesel	10.5 liter (11.1 qt)	 <b>CAUTION</b> <b>Additives may damage the cooling system. Before using additives, contact your local Hyster dealer.</b>  Trucks built prior to May 2021, use either a 50% water/50% ethylene-glycol boron free, silicate free mixture or BASF® Glysantin® G40 coolant. Protects cooling system down to -37°C (-34.6°F)  Trucks built after May 2021, use Valvoline Zerex G40 coolant. Protects cooling system down to -37°C (-34.6°F)
Yanmar 2.2L LPG		
Yanmar 3.0-3.3L diesel	11.5 liter (12.2 qt)	 <b>CAUTION</b> <b>Additives may damage the cooling system. Before using additives, contact your local Hyster dealer.</b>  Trucks built prior to May 2021, use either a 50% water/50% ethylene-glycol boron free, silicate free mixture or BASF® Glysantin® G40 coolant. Protects cooling system down to -37°C (-34.6°F)  Trucks built after May 2021, use Valvoline Zerex G40 coolant. Protects cooling system down to -37°C (-34.6°F)

**HEATING VENTILATION AND AIR  
CONDITIONING (HVAC) SPECIFICATIONS**

*Table 3. Air conditioning system*

Refrigerant type	Capacity
R134a	1.1 kg (2.4 lb)

*Table 4. Air conditioning compressor*

Oil type	Capacity
SP-10 PAG	100cc

*Table 5. R134a*

Ambient air temperature °C (°F)	Relative Humidity (%)	Gauge pressure		Outlet air temperature °C (°F)
		Low side kPa (psi)	High side kPa (psi)	
13 to 16°C (55 to 56°F)	0-100	175 to 206 kPa (25 to 30 psi)	340 to 850 kPa (49 to 123 psi)	7°C (45°F)
19 to 24°C (66 to 75°F)	<40	175 to 215 kPa (25 to 31 psi)	430 to 930 kPa (62 to 135 psi)	6°C (43°F)
	>40	175 to 254 kPa (25 to 37 psi)	570 to 1070 kPa (83 to 155 psi)	9°C (48°F)
25 to 29°C (76 to 85°F)	<35	175 to 249 kPa (25 to 36 psi)	760 to 1410 kPa (110 to 205 psi)	9°C (48°F)
	35-60	175 to 261 kPa (26 to 38 psi)	830 to 1180 kPa (120 to 171 psi)	10°C (50°F)
	>60	185 to 286 kPa (27 to 42 psi)	880 to 1250 kPa (128 to 181 psi)	11°C (52°F)
30 to 35°C (86 to 95°F)	<30	193 to 293 kPa (28 to 43 psi)	1010 to 1410 kPa (146 to 205 psi)	12°C (54°F)
	30-50	228 to 269 kPa (33 to 39 psi)	1050 to 1440 kPa (152 to 209 psi)	13°C (55°F)
	>50	221 to 324 kPa (32 to 47 psi)	1100 to 1470 kPa (160 to 213 psi)	14°C (57°F)
36 to 41°C (96 to 105°F)	<20	241 to 337 kPa (35 to 49 psi)	1310 to 1700 kPa (190 to 247 psi)	16°C (61°F)
	20-40	247 to 345 kPa (36 to 50 psi)	1320 to 1700 kPa (191 to 247 psi)	16°C (61°F)
	>40	259 to 353 kPa (38 to 51 psi)	1350 to 1690 kPa (196 to 245 psi)	16°C (61°F)

**Table 5. R134a (Continued)**

Ambient air temperature °C (°F)	Relative Humidity (%)	Gauge pressure		Outlet air temperature °C (°F)
		Low side kPa (psi)	High side kPa (psi)	
42 to 46°C (106 to 115°F)	<20	292 to 378 kPa (42 to 55 psi)	1630 to 1950 kPa (236 to 283 psi)	17°C (63°F)
	>20	297 to 383 kPa (43 to 56 psi)	1620 to 1930 kPa (235 to 280 psi)	19°C (66°F)
47 to 49°C (116 to 120°F)	<30	338 to 405 kPa (49 to 59 psi)	1870 to 2080 kPa (271 to 302 psi)	20°C (68°F)

## Torque specifications

### FRAME TORQUE SPECIFICATIONS

#### 202001-184

Capscrew (RH frame to rear frame)  
275 to 285 N•m (203 to 210 lbf ft)

Capscrew (LH frame to rear frame)  
275 to 285 N•m (203 to 210 lbf ft)

Capscrew (RH frame to front frame)  
97 N•m (71.5 lbf ft)

Capscrew (LH frame to front frame)  
97 N•m (71.5 lbf ft)

### ENERGY, ELECTRICAL, AND CONTROLS SYSTEMS TORQUE SPECIFICATIONS

#### 202001-185

Tilt position magnet  
19.2 N•m (14.2 lbf in)

Tilt position sensor to bracket  
0.9 N•m (8.0 lbf in)

Oil pressure sensor to engine  
9 N•m (80 lbf in)

ECT sensor  
25-34 N•m (18-25 lbf ft)

TPS sensor  
2.25 N•m (20 lbf in)

EGT sensor  
34.3 to 44.1 N•m (25.3 to 32.5 lbf ft)

Mast height sensor  
2.3 N•m (20.4 lbf in)

Mast height sensor cable  
10.9 N•m (96.5 lbf in)

Steer axle sensor harness  
3.5-4.0 N•m (31.0-35.4 lbf in)

Service brake pedal sensor  
2.25 N•m (19.9 lbf in)

Service brake position sensor  
23-28 N•m (17-21 lbf ft)

Service E-brake position sensor  
6.2 N•m (55 lbf in)

Low coolant level sensor into radiator  
7-9 N•m (62-80 lbf in)

Fuel level sensor manifold to fuel tank capscrews  
14.0 N•m (10.3 lbf ft)

Impact sensor to mounting bracket capscrews  
10.5 N•m (93 lbf in)

Load weight sensor  
10-20 N•m (7.4 to 14.8 lbf ft)

CAN bus interface unit capscrews  
4.17 N•m (37 lbf in)

Object detection side sensor capscrew  
14.3 N•m (10.5 lbf ft)

PDM to bracket capscrew  
10.5 N•m (93 lbf in)

Battery hold down link  
2.0 to 2.5 N•m (18 to 22 lbf in)

Strobe light mounting bracket capscrews  
6.2 N•m (55 lbf in)

Spot light mounting bracket capscrews  
5.0 N•m (44.3 lbf in)

Front work light mounting nuts  
5.0 N•m (44.3 lbf in)

User interface display mounting bracket capscrews  
25.6 N•m (19 lbf ft)

Armrest to mounting bracket capscrews  
13 to 15 N•m (115 to 132 lbf in)

Rear handle capscrews  
2.55 to 2.75 N•m (22.6 to 24.3 lbf in)

## FRONT END TORQUE SPECIFICATIONS 202001-186

### CARRIAGE

2 Stage LFL, 2 Stage FFL, and 3 Stage FFL  
Lower mounting hook capscrews  
150 to 180 N•m (111 to 133 lbf ft)

4 Stage FFL Lower mounting hook capscrews  
165 ±15 N•m (121 ±11 lbf ft)

Load backrest mounting nuts  
53 N•m (39.1 lbf ft)

### BOLZONI FORK POSITIONER

Fork lock screws  
84 N•m (62 lbf ft)

Fork carrier bushing screws  
69 N•m (51 lbf ft)

Actuator valve fittings  
20 N•m (15 lbf ft)

Side mounting screws  
142 N•m (105 lbf ft)

### MAST 2 STAGE FFL

Lowering control valve capscrews  
25.2 N•m (18.6 lbf ft)

Main lift cylinder mounting isolator nuts  
25.2 N•m (18.6 lbf ft)

Free lift cylinder mounting bracket nuts  
81.5 N•m (60 lbf ft)

Free lift cylinder chain sheave capscrew  
66 N•m (49 lbf ft)

Outer mast lube capscrew  
17 N•m (12.5 lbf ft)

Mast pivot pins  
270 N•m (199 lbf ft)

Anchor pin capscrew  
38 N•m (28 lbf ft)

Free-lift header hose roller capscrew  
16 N•m (11.8 lbf ft)

Upper bracket (mid-outer crossmember) capscrew  
25.2 N•m (18.6 lbf ft)

Manifold mounting capscrews  
19.2 N•m (14.2 lbf ft)

Mast bushing lube capscrew  
6 N•m (53.1 lbf in)

### MAST 3 STAGE FFL

Manifold mounting capscrews  
19.2 N•m (14.2 lbf ft)

Main lift cylinder mounting isolator nuts  
25.2 N•m (18.6 lbf ft)

Free lift cylinder mounting bracket nuts  
81.5 N•m (60 lbf ft)

Free lift cylinder chain sheave capscrew  
66 N•m (49 lbf ft)

Outer mast lube capscrew  
17 N•m (12.5 lbf ft)

Mast pivot pins  
270 N•m (199 lbf ft)

Anchor pin capscrew  
38 N•m (28 lbf ft)

Free-lift header hose roller capscrew  
16 N•m (11.8 lbf ft)

Upper bracket (mid-outer crossmember) capscrew  
25.2 N•m (18.6 lbf ft)

Mast bushing lube capscrew  
6 N•m (53.1 lbf in)

### MAST 2 STAGE LFL

Manifold mounting capscrews  
19.2 N•m (14.2 lbf ft)

Main lift cylinder mounting isolator nuts  
25.2 N•m (18.6 lbf ft)

Outer mast lube capscrew  
17 N•m (12.5 lbf ft)

Mast pivot pins  
270 N•m (199 lbf ft)

Anchor pin capscrew  
38 N•m (28 lbf ft)

Mast bushing lube capscrew  
6 N·m (53.1 lbf in)

## MAST 4 STAGE FFL

Manifold mounting capscrews  
19.2 N·m (14.2 lbf ft)

Main lift cylinder mounting isolator nuts  
25.2 N·m (18.6 lbf ft)

Free lift cylinder mounting bracket nuts  
81.5 N·m (60 lbf ft)

Free lift cylinder chain sheave capscrew  
66 N·m (49 lbf ft)

Outer mast lube capscrew  
17 N·m (12.5 lbf ft)

Mast pivot pins  
270 N·m (199 lbf ft)

Anchor pin capscrew  
38 N·m (28 lbf ft)

Free-lift header hose roller capscrew  
16 N·m (11.8 lbf ft)

Upper bracket (mid-outer crossmember) capscrew  
25.2 N·m (18.6 lbf ft)

Mast bushing lube capscrew  
6 N·m (53.1 lbf in)

## HYDRAULIC TORQUE SPECIFICATIONS 202001-187

Rear valve housing to gear pump capscrews  
46-49 N·m (34-36 lbf ft)

Hydraulic gear pump capscrews  
52 N·m (38.4 lbf ft)

Variable Displacement Pump capscrews  
90 N·m (66.4 lbf ft)

Margin pressure adjustment plug setscrew  
9 N·m (7 lbf ft)

Control valve to frame capscrews  
19.2 N·m (14.2 lbf ft)

Tilt cylinder piston nut  
• 170 to 220 N·m (125 to 162 lbf ft) for H2.0A, H2.5A6, H2.5A (H40A, H50A6) (R177)

Tilt cylinder piston nut  
• 320 to 400 N·m (236 to 295 lbf ft) for H3.0A, H3.5A (H60A, H70A) (R177)

Tilt cylinder gland  
• 170 to 220 N·m (125 to 162 lbf ft) for H2.0A, H2.5A6, H2.5A (H40A, H50A6) (R177)  
• 320 to 400 N·m (236 to 295 lbf ft) for H3.0A, H3.5A (H60A, H70A) (R177)

Tilt cylinder anchor pin  
38 N·m (28 lbf ft)

Tilt cylinder mounting capscrews  
90 N·m (66 lbf ft)

Lift cylinder piston (2 stage LFL)  
170 to 200 N·m (125 to 148 lbf ft)

Lift cylinder gland (2 stage LFL)  
340 to 410 N·m (251 to 302 lbf ft)

Lift cylinder to chain support anchor capscrew (2 stage LFL)  
40 N·m (30 lbf ft)

Lift cylinder piston (2 stage FFL)  
170 to 200 N·m (125 to 148 lbf ft)

Lift cylinder gland (2 stage FFL)  
340 to 410 N·m (251 to 302 lbf ft)

Lift cylinder mounting capscrew (2 stage FFL)  
40 N·m (30 lbf ft)

Lift cylinder piston (3 stage FFL)  
140 to 200 N·m (103 to 148 lbf ft)

Lift cylinder gland (3 stage FFL)  
340 to 410 N·m (251 to 302 lbf ft)

Lift cylinder mounting capscrew (3 stage FFL)  
40 N·m (30 lbf ft)

Free-lift cylinder gland  
475 to 540 N·m (350 to 398 lbf ft)

Free-lift cylinder crosshead capscrews  
435 N·m (321 lbf ft)

Free-lift cylinder crossmember nuts  
53 N·m (39 lbf ft)

Free-lift chain guard capscrews  
38 N·m (28 lbf ft)

## OPERATOR STATION TORQUE SPECIFICATIONS 202001-188

### RECTANGLE OVERHEAD GUARD

Front overhead guard legs capscrews  
225 to 250 N·m (166 to 184.4 lbf ft)

Rear overhead guard legs spacers to frame capscrews  
54 to 60 N·m (39.8 to 44.3 lbf ft)

Rear overhead guard legs capscrews  
225 to 250 N·m (166 to 184.4 lbf ft)

### FIGURE 8 OVERHEAD GUARD

Front overhead guard legs spacers to frame capscrews  
54 to 60 N·m (39.8 to 44.3 lbf ft)

Front overhead guard legs capscrews  
100 to 113 N·m (73.8 to 83.3 lbf ft)

Rear overhead guard legs spacers to frame capscrews  
54 to 60 N·m (39.8 to 44.3 lbf ft)

Rear overhead guard legs capscrews  
100 to 113 N·m (73.8 to 83.3 lbf ft)

RH and LH seat rail bolts  
25 N·m (18.4 lbf ft)

RH armrest nut  
9 to 13 N·m (6.6 to 9.6 lbf ft)

Master cylinder clevis nut  
17 to 23 N·m (13 to 17 lbf ft)

Park brake assembly mounting bolts  
19.2 N·m (14.2 lbf ft)

## DRIVETRAIN TORQUE SPECIFICATIONS 202001-189

### ENGINE - YANMAR 2.1L DIESEL

Engine mounting bolts  
220 to 230 N·m (162 to 170 lbf ft)

Cylinder head bolt  
First pass - 49 to 59 N·m (36 to 43 lbf ft)  
Second pass - 103 to 113 N·m (76 to 83 lbf ft)

Cylinder head bolt  
**See Yanmar Engines 0600SRM2299 for torque tightening sequence.**

Stator support capscrews  
First pass - 16 N·m (11.8 lbf ft)  
Second pass - 22 N·m (16.2 lbf ft)

Connecting rod bolts  
44.1 to 49 N·m (33 to 36 lbf ft)

Connecting rod to connecting rod cap bolts  
54 to 59 N·m (40 to 44 lbf ft)

Flywheel bolts  
83.3 to 88.2 N·m (61 to 65 lbf ft)

Main bearing cap bolt  
96 to 100 N·m (70.8 to 73.8 lbf ft)

Crankshaft pulley bolts  
112.7 to 122.7 N·m (83 to 91 lbf ft)

Fuel injector retaining bolt  
24.4 to 28.4 N·m (18 to 21 lbf ft)

Supply pump drive gear to drive shaft nut  
75 to 85 N·m (55 to 63 lbf ft)

Supply pump to gear case nuts  
22.6 to 28.4 N·m (16.7 to 20.9 lbf ft)

Supply pump cover  
22.6 to 28.4 N·m (16.7 to 20.9 lbf ft)

Fuel line nut (common rail)  
29.4 to 34.3 N·m (21.7 to 25.3 lbf ft)

Fuel line nut (injector)  
26.5 to 34.3 N·m (19.5 to 25.3 lbf ft)

Fuel line nut (supply pump)  
29.4 to 34.3 N·m (21.7 to 25.3 lbf ft)

Fuel injector retaining bolt  
24.4 to 28.4 N·m (18 to 20.9 lbf ft)

Common rail to intake manifold  
22.6 to 28.4 N·m (16.7 to 20.9 lbf ft)

Rail pressure sensor to common rail  
90 to 100 N·m (66.4 to 73.8 lbf ft)

Pressure limiting valve to common rail  
95 to 105 N·m (70.1 to 77.4 lbf ft)

Fuel filter bracket bolts  
35 to 43 N•m (25.8 to 31.7 lbf ft)

Crank rotation sensor  
6 to 10 N•m (4.4 to 7.4 lbf ft)

Cam speed sensor  
7.5 to 8.5 N•m (5.5 to 6.3 lbf ft)

EGR valve pipe  
18.9 to 24.7 N•m (14.0 to 18.2 lbf ft)

New air temperature sensor  
3.0 to 4.0 N•m (2.2 to 3.0 lbf ft)

Intake air temperature sensor  
11 to 17 N•m (8.1 to 12.5 lbf ft)

Exhaust air temperature sensor  
25 to 40 N•m (18.4 to 29.5 lbf ft)

DPF inlet temperature sensor  
45 to 55 N•m (33.2 to 40.6 lbf ft)

DPF inside temperature sensor  
45 to 55 N•m (33.2 to 40.6 lbf ft)

DPF differential pressure sensor  
5.6 to 8.4 N•m (4.1 to 6.2 lbf ft)

DPF differential pressure sensor pipe joint bolt  
24.5 to 34.3 N•m (18.1 to 25.3 lbf ft)

Cylinder head cover knob  
12 to 15 N•m (8.9 to 11 lbf ft)

Glow plug  
15 to 20 N•m (11.1 to 14.8 lbf ft)

Glow connector nut  
1 to 1.5 N•m (0.7 to 1.1 lbf ft)

Piston cooling nozzle banjo bolt  
12.7 to 16.7 N•m (9.4 to 12.3 lbf ft)

Engine to transmission assembly capscrews  
41 to 49 N•m (30.2 to 36.1 lbf ft)

Alternator harness to alternator nuts  
1.7 to 2.3 N•m (15 to 20.3 lbf in)

Soot filter to DOC flange bolts  
23 to 29 N•m (17 to 21 lbf ft)

Sensor bracket to soot filter flange bolts  
23 to 29 N•m (17 to 21 lbf ft)

Intake exhaust flange to DPF bolts  
44 to 54 N•m (32 to 40 lbf ft)

EGR lead valve screw  
1.35 to 1.39 N•m (11.9 to 12.3 lbf ft)

Fan mounting capscrews  
27 N•m (20 lbf ft)

Air intake bracket capscrews  
19.2 N•m (14.7 lbf ft)

## ENGINE - YANMAR 2.2L LPG

Cylinder head bolt  
First pass - 46 to 49 N•m (34 to 36 lbf ft)  
Second pass - 92 to 98 N•m (68 to 72 lbf ft)  
**See Yanmar Engines 0600SRM2299 for torque tightening sequence.**

Stator support capscrews  
First pass - 16 N•m (11.8 lbf ft)  
Second pass - 22 N•m (16.2 lbf ft)

Ignition coil bracket bolts  
24 to 34 N•m (17.7 to 25.1 lbf ft)

Ignition coil bolts  
6 to 9.5 N•m (4.4 to 7.0 lbf ft)

Exhaust manifold bolts  
44.1 to 53.9 N•m (32.5 to 39.8 lbf ft)

Exhaust manifold heat shield bolts  
22.6 to 28.4 N•m (16.7 to 21.0 lbf ft)

Exhaust manifold heat shield bolts  
22.6 to 28.4 N•m (16.7 to 21.0 lbf ft)

Intake throttle to intake manifold bolts  
22.6 to 28.4 N•m (16.7 to 21.0 lbf ft)

Intake manifold to engine block  
22.6 to 28.4 N•m (16.7 to 21.0 lbf ft)

Fuel rail to engine block  
7.8 to 9.4 N•m (5.8 to 6.9 lbf ft)

Connecting rod to connecting rod cap bolts  
54 to 59 N•m (40 to 44 lbf ft)

Flywheel bolts  
83.3 to 88.2 N•m (61 to 65 lbf ft)

Main bearing cap bolt  
First pass - 48 to 50 N•m (35.4 to 36.9 lbf ft)

Main bearing cap bolt Second pass - 96 to 100 N•m (70.8 to 73.8 lbf ft)	New air temperature sensor 3.0 to 4.0 N•m (2.2 to 3.0 lbf ft)
Crankshaft pulley bolts 112.7 to 122.7 N•m (83 to 91 lbf ft)	Intake air temperature sensor 11 to 17 N•m (8.1 to 12.5 lbf ft)
Fuel injector retaining bolt 24.4 to 28.4 N•m (18 to 21 lbf ft)	Exhaust air temperature sensor 25 to 40 N•m (18.4 to 29.5 lbf ft)
Fuel rail to exhaust manifold 4 to 6 N•m (3.0 to 4.4 lbf ft)	Cylinder head cover knob 12 to 15 N•m (8.9 to 11 lbf ft)
Fuel rail to intake manifold 7.8 to 9.4 N•m (5.8 to 6.9 lbf ft)	Spark plugs 24 to 34 N•m (17.7 to 25.1 lbf ft)
Supply pump drive gear to drive shaft nut 75 to 85 N•m (55 to 63 lbf ft)	Spark plug wire harness nut 1 to 1.5 N•m (8.9 to 13.3 lbf in)
Supply pump to gear case nuts 22.6 to 28.4 N•m (16.7 to 20.9 lbf ft)	Piston cooling nozzle banjo bolt 12.7 to 16.7 N•m (9.4 to 12.3 lbf ft)
Supply pump cover 22.6 to 28.4 N•m (16.7 to 20.9 lbf ft)	Engine to transmission assembly capscrews 41 to 49 N•m (30.2 to 36.1 lbf ft)
Fuel line nut (common rail) 29.4 to 34.3 N•m (21.7 to 25.3 lbf ft)	Alternator harness to alternator nuts 1.7 to 2.3 N•m (15.0 to 20.4 lbf in)
Fuel line nut (injector) 26.5 to 34.3 N•m (19.5 to 25.3 lbf ft)	Muffler capscrew 22.6 to 28.4 N•m (17 to 21 lbf ft)
Fuel line nut (supply pump) 29.4 to 34.3 N•m (21.7 to 25.3 lbf ft)	Catalytic converter to exhaust pipe nuts 39 N•m (28.8 lbf ft)
Fuel injector retaining bolt 24.4 to 28.4 N•m (18 to 20.9 lbf ft)	Muffler to exhaust pipe nuts 39 N•m (28.8 lbf ft)
Common rail to intake manifold 22.6 to 28.4 N•m (16.7 to 20.9 lbf ft)	Tailpipe to muffler clamp nuts 19 N•m (14 lbf ft)
Rail pressure sensor to common rail 90 to 100 N•m (66.4 to 73.8 lbf ft)	EGR lead valve screw 1.35 to 1.39 N•m (11.9 to 12.3 lbf ft)
Pressure limiting valve to common rail 95 to 105 N•m (70.1 to 77.4 lbf ft)	Fan mounting capscrews 27 N•m (20 lbf ft)
Fuel filter bracket bolts 35 to 43 N•m (25.8 to 31.7 lbf ft)	Rear engine mounting bolt 59 to 61 N•m (43.5 to 45.0 lbf ft)
Crank rotation sensor 6 to 10 N•m (4.4 to 7.4 lbf ft)	Upper and lower engine mounting bolts 101 to 105 N•m (74.5 to 77.4 lbf ft)
Cam speed sensor 7.5 to 8.5 N•m (5.5 to 6.3 lbf ft)	Air intake bracket capscrews 19.2 N•m (14.7 lbf ft)
EGR valve pipe 18.9 to 24.7 N•m (14.0 to 18.2 lbf ft)	

**TRANSMISSION**

Transmission drain plug

93 to 102 N·m (68.6 to 75.2 lbf ft)

Transmission assembly to engine capscrews

41 to 49 N·m (30.2 to 36.1 lbf ft)

Torque converter housing capscrews

32 to 36 N·m (23.6 to 26.6 lbf ft)

Transmission housing to torque converter housing  
flange bolts

First pass - 18 to 20 N·m (13.3 to 14.6 lbf ft)

Second pass - 24 to 26 N·m (17.7 to 19.2 lbf ft)

**See Yanmar Engines 0600SRM2299 Drive Train 0900SRM2301 for torque tightening sequence.**

Baffle plate capscrews (Electronic Powershift transmission)

19 to 25 N·m (14.01 to 18.44 lbf ft)

Stator (Electronic Powershift transmission)

First pass - 18 to 20 N·m (13.3 to 14.6 lbf ft)

Second pass - 24 to 26 N·m (17.7 to 19.2 lbf ft)

**See Drive Train 0900SRM2301 for torque tightening sequence.**

Charge pump capscrews (Electronic Powershift transmission)

First pass - 18 to 20 N·m (13.3 to 14.6 lbf ft)

Second pass - 24 to 26 N·m (17.7 to 19.2 lbf ft)

**See Drive Train 0900SRM2301 for torque tightening sequence.**

Cooling pump screws (HST transmission)

93 to 102 N·m (68.6 to 75.2 lbf ft)

**DRIVE AXLE (DRY BRAKE)**

Drive axle mounting capscrews

415 to 455 N·m (306.1 to 335.6 lbf ft)

Drive axle capscrews

255 to 306 N·m (188 to 226 lbf ft)

Drive axle hanger capscrews

90 to 108 N·m (66 to 80 lbf ft)

Drive shaft capscrews

90 to 108 N·m (66 to 80 lbf ft)

Drive shaft to drive axle capscrews

32 to 36 N·m (23.6 to 26.6 lbf ft)

Drive shaft to input yoke capscrews

32 to 36 N·m (23.6 to 26.6 lbf ft)

Drive axle drain plug

35 to 50 N·m (25.8 to 36.9 lbf ft)

Drive wheel nuts (M18)

339 to 380 N·m (250 to 280 lbf ft)

Drive wheel nuts (M20)

400 to 500 N·m (295 to 369 lbf ft)

**DRIVE AXLE (WET BRAKE)**

Drive axle mounting capscrews

415 to 455 N·m (306.1 to 335.6 lbf ft)

Drive axle hanger capscrews

270 N·m (199 lbf ft)

Drive shaft capscrews

90 to 108 N·m (66 to 80 lbf ft)

Drive shaft to drive axle capscrews

32 to 36 N·m (23.6 to 26.6 lbf ft)

Drive shaft to input yoke capscrews

32 to 36 N·m (23.6 to 26.6 lbf ft)

Drive axle drain plug

50 to 55 N·m (37 to 41 lbf ft)

Drive wheel nuts

339 to 380 N·m (250 to 280 lbf ft)

**BRAKES**

Drive axle back plate capscrews

255 to 306 N·m (188 to 226 lbf ft)

Wheel cylinder

18 to 27 N·m (13 to 20 lbf ft)

Brake master cylinder push rod

17 to 23 N·m (13 to 17 lbf ft)

**PARK BRAKE**

Jam nuts

17 to 19 N·m (12.5 to 14 lbf ft)

Park brake mounting capscrews

78 to 84 N·m (57.5 to 62 lbf ft)

**STEERING AXLE**

Spindle nut

12 to 15 N•m (8.9 to 11.1 lbf ft)

Steer axle mounting bracket capscrews

90 N•m (66.4 lbf ft)

Wheel adjustment nut

To align bearing rollers -

14 to 18 N•m (12.4 to 15.9 lbf in)

To seat wheel bearings -

175 to 215 N•m (188 to 226 lbf ft)

Wheel nuts

155 to 175 N•m (114 to 129 lbf ft)

Bearing cap capscrews

44 to 55 N•m (32.5 to 40.6 lbf ft)

Steer cylinder to steer axle

225 to 280 N•m (166 to 206.5 lbf ft)



**TECHNICAL PUBLICATIONS**